



Logix 520si Series
Digital Positioner

FCD LGENIM2520-00 09/09

USER INSTRUCTIONS

Installation
Operation
Maintenance



Experience In Motion

Table of Contents	Page
General Information	2
Unpacking	3
Logix 520si Overview	4
Specifications	4
Principle of Operation	5
Tubing	6
Wiring	6
Cable Requirements	7
Startup	8
Logix 520si Local Interface Operation	8
Operation of Configuration Dipswitch Setup	8
Calibrations switches	9
Quick-Cal Operation	9
Factory Reset	10
Error Codes	12
Trouble Shooting	15
Limit switches	16
Spare parts	17
Dimensions	18

1 USING FLOWSERVE VALVES, ACTUATORS AND ACCESSORIES CORRECTLY

1.1 General usage

The following instructions are designed to assist in unpacking, installing and performing maintenance as required on FLOWSERVE products. Product users and maintenance personnel should thoroughly review this bulletin prior to installing, operating or performing any maintenance.

In most cases FLOWSERVE valves, actuators and accessories are designed for specific applications with regard to medium, pressure and temperature. For this reason they should not be used in other applications without first contacting the manufacturer.

1.2 Terms concerning safety

The safety terms **DANGER**, **WARNING**, **CAUTION** and **NOTE** are used in these instructions to highlight particular dangers and/or to provide additional information on aspects that may not be readily apparent.



DANGER: indicates that death, severe personal injury and/or substantial property damage will occur if proper precautions are not taken.



WARNING: indicates that death, severe personal injury and/or substantial property damage can occur if proper precautions are not taken.



CAUTION: indicates that minor personal injury and/or property damage can occur if proper precautions are not taken.



NOTE: indicates and provides additional technical information, which may not be very obvious even to qualified personnel.

Compliance with other, not particularly emphasised notes, with regard to transport, assembly, operation and maintenance and with regard to technical documentation (e.g. in the operating instruction, product documentation or on the product itself) is essential, in order to avoid faults, which in themselves might directly or indirectly cause severe personal injury or property damage.

1.3 Protective clothing

FLOWSERVE products are often used in problematic applications (e.g. extremely high pressures, dangerous, toxic or corrosive mediums). In particular valves with bellows seals point to such applications. When performing service, inspection or repair operations always ensure, that the valve and actuator are depressurised and that the valve has been cleaned and is free from harmful substances. In such cases pay particular attention to personal protection (protective clothing, gloves, glasses etc.).

1.4 Qualified personnel

Qualified personnel are people who, on account of their training, experience and instruction and their knowledge of relevant standards, specifications, accident prevention regulations and operating conditions, have been authorised by those responsible for the safety of the plant to perform the necessary work and who can recognise and avoid possible dangers.

1.5 Installation



DANGER: Before installation check the order-no., serial-no. and/or the tag-no. to ensure that the valve/actuator is correct for the intended application.

Do not insulate extensions that are provided for hot or cold services.

Pipelines must be correctly aligned to ensure that the valve is not fitted under tension.

Fire protection must be provided by the user.

1.6 Spare parts

Use only FLOWSERVE original spare parts. FLOWSERVE cannot accept responsibility for any damages that occur from using spare parts or fastening materials from other manufactures. If FLOWSERVE products (especially sealing materials) have been on store for longer periods check these for corrosion or deterioration before using these products. Fire protection for FLOWSERVE products must be provided by the end user.

1.7 Service / repair

To avoid possible injury to personnel or damage to products, safety terms must be strictly adhered to. Modifying this product, substituting nonfactory parts, or using maintenance procedures other than outlined in this instruction could drastically affect performance and be hazardous to personnel and equipment, and may void existing warranties. Between actuator and valve there are moving parts. To avoid injury FLOWSERVE provides pinch-point-protection in the form of cover plates, especially where side-mounted positioners are fitted. If these plates are removed for inspection, service or repair special attention is required. After completing work the cover plates must be refitted.

Apart from the operating instructions and the obligatory accident prevention directives valid in the country of use, all recognised regulations for safety and good engineering practices must be followed.



WARNING: *Before products are returned to FLOWSERVE for repair or service FLOWSERVE must be provided with a certificate which confirms that the product has been decontaminated and is clean. FLOWSERVE will not accept deliveries if a certificate has not been provided (a form can be obtained from FLOWSERVE).*

1.8 Storage

In most cases FLOWSERVE products are manufactured from stainless steel. Products not manufactured from stainless steel are provided with an epoxy resin coating. This means that FLOWSERVE products are well protected from corrosion. Nevertheless FLOWSERVE products must be stored adequately in a clean, dry environment. Plastic caps are fitted to protect the flange faces to prevent the ingress of foreign materials. These caps should not be removed until the valve is actually mounted into the system.

1.9 Valve and actuator variations

These instructions cannot claim to cover all details of all possible product variations, nor can they provide information for every possible example of installation, operation or maintenance. This means that the instructions normally include only the directions to be followed by qualified personal where the product is being used for is defined purpose. If there are any uncertainties in this respect particularly in the event of missing product-related information, clarification must be obtained via the appropriate FLOWSERVE sales office.

2 UNPACKING

Each delivery includes a packing slip. When unpacking, check all delivered valves and accessories using this packing slip.

Report transport damage to the carrier immediately.

In case of discrepancies, contact your nearest FLOWSERVE location.

3 LOGIX 520SI OVERVIEW

The Logix 520si is a two-wire, 4-20 mA input digital valve positioner. The Logix 520 also utilizes the HART protocol to allow two-way remote communication with the positioner. The Logix 520si positioner controls single-acting actuators with linear and rotary mountings. The Logix 520si is completely powered by the 4-20 mA input signal. The minimum input signal required to function is 3,6 mA. As the positioner is insensitive to supply pressure changes and can handle supply pressures from 1,5 to 6 barg (22 to 87 psig), a supply regulator is usually

not required; however, in applications where the supply pressure is higher than the maximum actuator pressure rating a supply regulator is required to lower the pressure to the actuator's maximum rating (not to be confused with operating range). A coalescing air filter is recommended for all applications due to the close tolerances in the positioner. Optional limit switch unit and a directly attachable double acting module complete the Logix 520si positioner accessories.

4 SPECIFICATIONS

Table 1: Input Signal

Input Signal Range	4 - 20 mA (HART)
Compliance Voltage	12 VDC
Voltage Supply (maximum)	30 VDC
Minimum Required Operating Current	3,6 mA

Table 2: Stroke Output

Feedback Shaft Rotation	Min. 15°, max 90° 40° recommended for linear applications
-------------------------	--

Table 3: Air Supply

Air Supply Quality	Free from moisture, oil and dust per IEC 770 and ISA-7.0.01
Input Pressure Range	1,5 to 6,0 bar (22 to 87 psi)
Air Consumption (steady state)	0,08 Nm ³ /h @ 1,5 bar (0,047 SCFM @ 22 psi) 0,12 Nm ³ /h @ 6,0 bar (0,071 SCFM @ 87 psi)

Table 4: Output Signal

Output Pressure Range	0 to 100% of air supply pressure
Output Flow Capacity	2,4 Nm ³ /h @ 1,5 bar (1,41 SCFM @ 22 psi) 7,0 Nm ³ /h @ 6,0 bar (4,12 SCFM @ 87 psi)

Table 5: Shipping Weights

Base Positioner without Accessories	1,2 kg (2,65 lbs)
-------------------------------------	-------------------

Table 6: Performance Characteristics (typical)

Linearity	< +/- 1,0%
Resolution	< 0,1%
Repeatability	< 0,2%
Deadband	< 0,2%

Table 7: Environmental Conditions

Operating Temperature Standard	-20 °C to +80 °C (-4 °F to +178 °F)
Operating Temperature Low	-40 °C to +80 °C (-40 °F to +178 °F)
Transport and Storage Temperature	-40 °C to +80 °C (-40 °F to +178 °F)
Operating Humidity	0 to 100% non-condensing

Table 8: Hazardous Area Specifications

ATEX	II1G Ex ia IIC T4 - T6 II3G Ex ic IIC T4 - T6
FM	Class I, Division 2, Groups A,B,C,D Temp. Class. T4 Ta = 85°C Class I Zone = Group IIC T4 Ta = 85°C Class I, Division 2, Groups A,B,C,D Temp. Class. T4 Ta = 85°C
CSA	Class I Division 1, Groups A,B,C,D Class I Division 2, Groups A,B,C,D

Table 9: Limit Switches (optional)

Type	P&F SJ2-S1N
Load current	< 1 mA < 3 mA
Voltage range	5 - 25 VDC
Hysteresis	0,2 %
Temperature	-25 °C to 100 °C (-13 °F to 212 °F)
Type	P&F SJ2-SN
Load current	< 1 mA < 3 mA
Voltage range	5 - 25 VDC
Hysteresis	0,2 %
Temperature	-40 °C to 100 °C (-40 °F to 212 °F)
Type	P&F SJ2-N
Load current	< 1 mA < 3 mA
Voltage range	5 - 25 VDC
Hysteresis	0,2 %
Temperature	-25 °C to 100 °C (-13 °F to 212 °F)

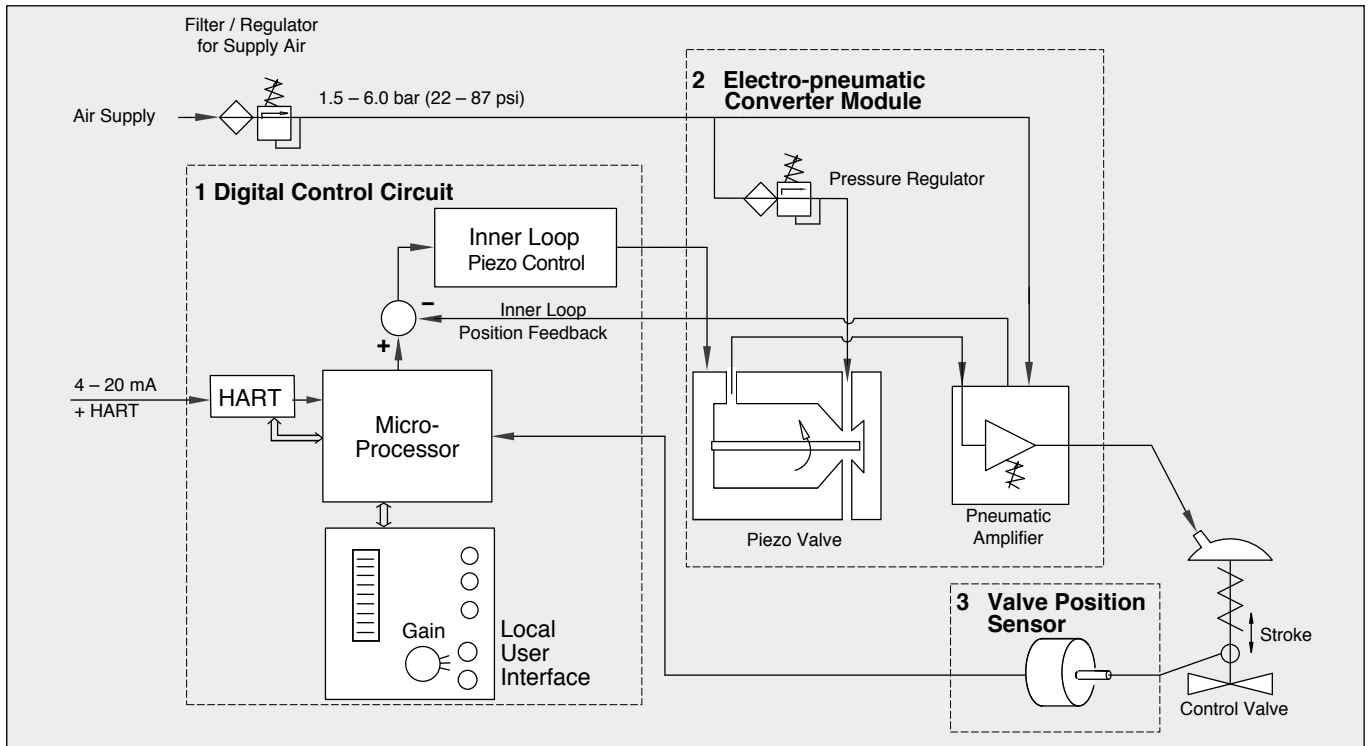

Figure 1: Logix 520si Principle of Operation

NOTE: The air supply must conform to ISA 7.0.01 or IEC 770 (a dew point at least 10 °C / 18 °F below ambient temperature, particle size below five microns – one micron recommended – and oil content not to exceed one part per million).

5 PRINCIPLE OF OPERATION

The Logix 520si positioner is a digital positioner that incorporates HART protocol for communication. The positioner consists of three main modules:

1. The microprocessor-based electronic control module includes HART communications and direct local user interface switches
2. The piezo valve-based electro-pneumatic converter module
3. The infinite resolution valve position sensor.

The basic positioner operation is best understood by referring to Figure 1. The complete control circuit is powered by the two-wire, 4-20 mA command signal. The HART module sends and receives the superimposed FSK HART digital communications over the 4-20 mA signal wires providing two-way remote digital communications to the microprocessor. The analog 4-20 mA command is passed to the microprocessor, where it is compared to the measured valve stem position. The control algorithm in the processor performs

control calculations and produces an output command to the piezo valve, which drives the pneumatic amplifier. The position of the pilot valve in the pneumatic amplifier is measured and relayed to the inner loop control circuit. This two-stage control provides for more responsive and tighter control than is possible with a single stage control algorithm. The pneumatic amplifier controls the airflow to the actuator. The change of pressure and volume of the air in the actuator causes the valve to stroke. As the valve approaches the desired position, the difference between the commanded position and the measured position becomes smaller and the output to the piezo is decreased. This, in turn, causes the pilot valve to close and the resulting flow to decrease, which slows the actuator movement as it approaches, the new commanded position. When the valve actuator is at the desired position, the pneumatic amplifier output is held at zero, which holds the valve in a constant position.

6 TUBING POSITIONER TO ACTUATOR

After mounting has been completed, tube the positioner to the actuator using the appropriate compression fitting connectors:

- Air connections:** 1/4" NPT (standard air connection)
- Auxiliary power:** Pressurized air or permissible

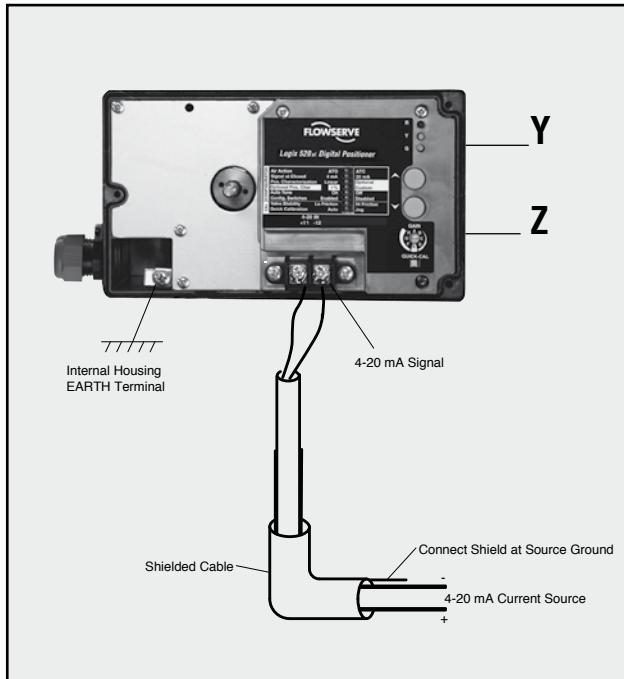

Figure 2: Wiring Diagram

gases, free of moisture and dust in according with IEC 770 or ISA 7.0.01.

Pressure range: 1,5 – 6,0 bar (22 – 87 psi)

For connecting the air piping, the following notes should be observed:

1. The positioner passageways are equipped with filters, which remove medium and coarse size dirt from the pressurized air. If necessary, they are easily accessible for cleaning.
2. Supply air should meet IEC 770 or ISA 7.0.01 requirements. A coalescing filter should be installed in front of the supply air connection Z. Now connect the air supply to the filter, which is connected to the Logix 500si series positioner.
3. With a maximum supply pressure of 6 bar (87 psi) a regulator is not required.
4. With an operating pressure of more than 6 bar (87 psi), a reducing regulator is required. The flow capacity of the regulator must be larger than the air consumption of the positioner (7 Nm³/hr @ 6 bar / 4,12 scfm @ 87 psi).
5. Connect the outlet connector Y of the positioner to the actuator with tubing, independent of the action (direct or reverse).

Table 10: Connection Table

Connection	Description
+11	Input+ 4..20 mA
-12	Input- 4..20 mA
	Limit switch 1 - separate board
	Limit switch 2 - separate board
Y (0⇒)	Pneumatic output signal (outlet)
Z (0⇐)	Air supply

* Optional

7 WIRING AND GROUNDING GUIDELINES

Electrical connections: signal cable with cable passage (NPT or M20 x 1,5) to terminals 2 x 2,5 mm

Input signal: 4 – 20 mA

! **NOTE:** Observe the minimum requirements of voltage and equivalent electrical load: 12 VDC / 600 Ω / at 20 mA

The performance is ensured only for a minimum input current of 3,6 mA.

For wiring, the following notes should be observed:

! **NOTE:** The input loop current signal to the Logix 520si should be in shielded cable. Shields must be tied to a ground at only one end of the cable to provide a place for environmental electrical noise to be removed from the cable. In general, shield wire should be connected at the source. (Figure 2)

Connect the 4-20 mA current source to terminals +11 and -12 (Figure 2).

Grounding Screw

The grounding screw, located inside the positioner cover, should be used to provide the unit with an adequate and reliable earth ground reference. This ground should be tied to the same ground as the electrical conduit. Additionally, the electrical conduit should be earth grounded at both ends of its run. The grounded screw must not be used to terminate signal shield wires.

Compliance Voltage (Figure 3)

Output compliance voltage refers to the voltage limit the current source can provide. A current loop system consists of the current source, wiring resistance, barrier resistance (if present), and the Logix 520si impedance. The Logix 520si requires that the current loop system allow for a 12 VDC drop across the positioner at maximum loop current.

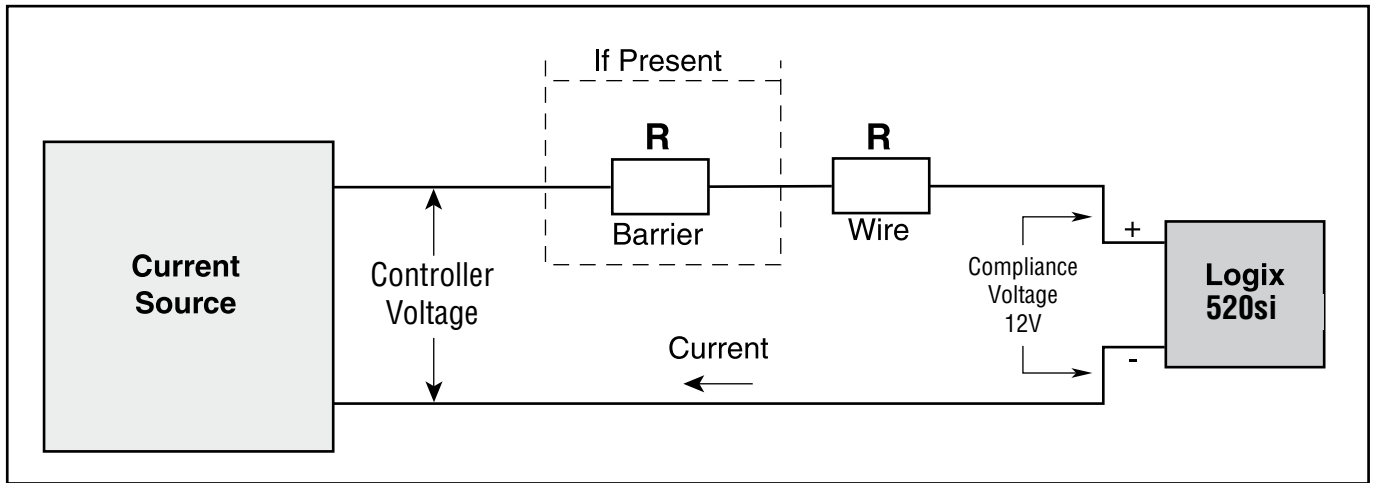

Figure 3: Compliance Voltage



CAUTION: Never connect a voltage source directly across the positioner terminals. This could cause permanent circuit board damage.

In order to determine if the loop will support the Logix 520si, perform the following calculation:

$$\text{Available Voltage} = \text{Controller Voltage (@Current}_{MAX}) - \text{Current}_{MAX} * (R_{barrier} + R_{wire})$$

The calculated available voltage must be greater than 12 VDC in order to support the Logix 520si.

Example:

DCS Controller Voltage = 19 V

$$R_{barrier} = 300\Omega$$

$$R_{wire} = 25 \Omega$$

$$\text{CURRENT}_{MAX} = 20 \text{ mA}$$

$$\begin{aligned} \text{Voltage} &= 19 \text{ V} - 0,020 \text{ A} * (300\Omega + 25 \Omega) \\ &= \underline{12,5 \text{ V}} \end{aligned}$$

The available voltage 12,5 V is greater than the required 12 V; therefore, this system will support the Logix 520si. The Logix 520si has an input resistance equivalent to 500 Ω at a 20 mA input current.

8 CABLE REQUIREMENTS

The Logix 520si digital positioner utilizes the HART communication protocol. This communication signal is superimposed on the DC 4-20 mA current signal. The two frequencies used by the HART protocol are 1200 Hz and 2200 Hz. To prevent distortion of the HART communication, cable capacitance and cable length restrictions must be calculated. The cable length must be limited if the capacitance is too high. Selecting a cable with lower capacitance/mm

rating will allow longer cable runs. In addition to cable capacitance, the network resistance also affects the allowable cable length.

$$C_{network} (\mu F) \leq \frac{65\Omega}{(R_{barrier} + R_{wire} + 390\Omega)} - 0,0032$$

Example:

$$R_{barrier} = 300 \Omega \text{ (if present)}$$

$$R_{wire} = 50 \Omega$$

$$C_{cable} = \frac{72 \rho F}{m} = \frac{0.000072 \mu F}{m}$$

$$\left[\frac{65}{(300 + 50 + 390)} \right] - 0,0032 = 0,08 \mu F = C_{network} (\mu F) (\text{Max})$$

$$\text{Max. Cable Length} = \frac{C_{network} (\mu F)}{C_{cable}}$$

$$\text{Max. Cable Length} = \frac{0,08 \mu F}{0.000072 \mu F/m} = 1111 \text{ m}$$

To control cable resistance, No. 24 AWG cable can be used for runs less than 1500 m. For cable runs longer than this, No. 20 AWG cable should be used.

Electromagnetic Compatibility

The Logix 520si digital positioner has been designed to operate correctly in electromagnetic (EM) fields found in typical industrial environments. Care should be taken to prevent the positioner from being used in environments with excessively high EM field strengths (greater than 10 V/m). Portable EM devices such as hand-held two-way radios should not be used within 30 cm of the device.

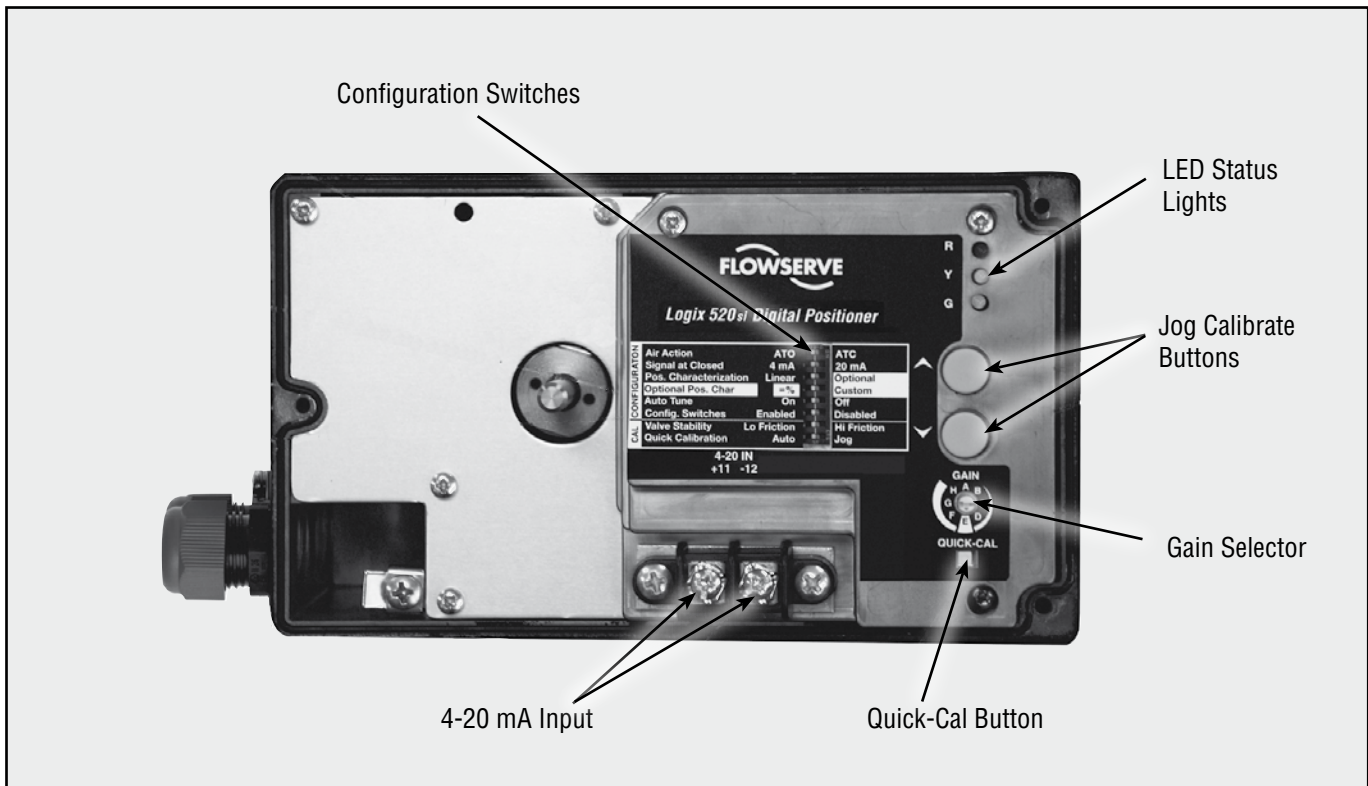

Figure 4: Logix 520si Local Interface

Ensure proper wiring and shielding techniques of the control lines, and route control lines away from electromagnetic sources that may cause unwanted noise. An electromagnetic line filter can be used to further eliminate noise (FLOWSERVE Part Number 10156843).

In the event of a severe electrostatic discharge near the positioner, the device should be inspected to ensure correct operability. It may be necessary to recalibrate the Logix 520si positioner to restore operation.

9 STARTUP

9.1 Logix 520si Local Interface

The Logix 520si local user interface allows the user to configure the basic operation of the positioner, tune the response, and calibrate the positioner without additional tools or configurators. The local interface consists of a Quick-Cal™ button for automatic zero and span setting, along with two jog buttons for spanning valve/actuators with no fixed internal stop in the open position. There is also a switch block containing eight switches. Six of the switches are for basic configuration settings, two are for calibration options. There is also a rotary selector switch for adjusting the positioner gain settings. For indication of operational status or alarm conditions there are three LEDs on the local user interface.

9.2 Initial DIP Switch Setting

Before placing the unit in service, set the DIP switches in the “Configuration” and “Cal” boxes to the desired control options.

NOTE: *The switch settings in the Configuration box are activated **only** by pressing the Quick-Cal button or by utilizing the stroke calibration features provided by a handheld or by Flowserve PC software.*

9.2 Operation of Configuration DIP Switches Setup

The first six DIP switches are for basic configuration

- 1. Air Action** – Must be set to match the configuration of the valve/actuator mechanical configuration.

ATO (air-to-open) – Select **ATO** if increasing output pressure from the positioner is tubed so it will cause the valve to **open**.

ATC (air-to-close) – Select **ATC** if increasing output pressure from the positioner is tubed so it will cause the valve to **close**.

- 2. Signal at Closed** – Normally this will be set to 4 mA for an air-to-open actuator, and 20 mA for an air-to-close actuator configuration.

Selecting **4 mA** will make the valve fully closed when the signal is 4 mA and fully open when the signal is 20 mA.

Selecting **20 mA** will make the valve fully closed when the signal is 20 mA and fully open when the signal is 4 mA.

3. Pos. Characterization

Select **Linear** if the actuator position should be directly proportional to the input signal.

Select **Optional** if another characteristic is desired, which is set in conjunction with the next switch, labeled **Optional Pos. Char.**

4. Optional Pos. Char. – If the **Pos. Characterization** switch is set to **optional**, this switch is active with the following options:

The **=%** option will characterize the actuator response to the input signal based on a standard 30:1 equal percent rangability curve.

If **Custom** is selected, the positioner will be characterized to a custom table that must be set-up ValveSight DTM software or a HART handheld.

5. Auto Tune – This switch controls whether the positioner will auto tune itself every time the Quick-Cal button is pressed

On enables an auto tune feature that will automatically determine the positioner gain settings every time a Quick-Cal is performed based on the setting of the rotary **Gain** switch.



NOTE: *there is a small black arrow indicating the selection. The slot does not indicate the chosen gain.*

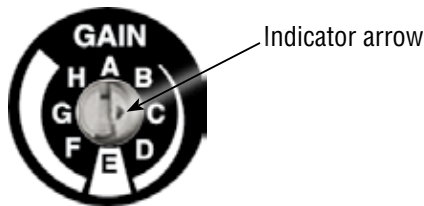

If the rotary **Gain** selector switch is set to **E** with the **Auto Tune** switch **On**, a Flowserve nominal response tuning set will be calculated and used.

If the rotary **Gain** selector switch is set to **D, C, B, or A** with the **Auto Tune** switch **On**, progressively lower gain settings will be calculated and used.

If the rotary **Gain** selector switch is set to **F, G, or H** with the **Auto Tune** switch **On**, progressively higher gain settings will be calculated and used.

Off forces the positioner to use one of the factory preset tuning sets determined by the rotary **Gain** selector switch. Settings **A** through **H** are progressively higher gain pre-defined tuning sets. The positioner is preset to Autotune - On at the factory. This is the recommended setting.

The gain selector operates as a “live” switch. This means that changes to the switch position while the positioner is in normal operation will have immediate effect on the control algorithm.

6. Stability Switch – This switch adjusts the position control algorithm of the positioner for use with low friction control

valves or high friction automated valves

Placing the switch to the left optimizes the response for low friction, high performance control valves. This setting provides for optimum response times when used with most low friction control valves.

Placing the switch to the right optimizes the response for valves and actuators with high friction levels. This setting slightly slows the response and will normally stop limit cycling that can occur on high friction valves.

9.3 Calibration switches

9.3.1 Setup of the Cal DIP Switch for the Quick

Calibration operating mode

Select **Auto** if the valve/actuator assembly has an internal stop in the 100% stroke position. In **Auto** mode the positioner will fully close the valve and register the 0% position and then open the valve to the stop to register the 100% position when performing a self-calibration. See detailed instructions in the next section on how to perform an auto positioner calibration.

Select **Jog** if the valve/actuator assembly has no calibration stop in the open position. In the **Jog** mode the positioner will fully close the valve for the 0% position and then wait for the user to set the open position using the **Jog** buttons labeled with the up and down arrows. See the detailed instructions in the next section on how to perform a manual calibration using the **Jog** buttons.



WARNING: *During the Quick-Cal operation the valve may stroke unexpectedly. Notify proper personnel that the valve will stroke, and make sure the valve is properly isolated.*

9.4 Quick-Cal Operation

The **Quick-Cal** button is used to locally initiate a calibration of the positioner. Pressing and holding the **Quick-Cal** button for approximately three seconds will initiate the calibration. If the **Config-Switches** option is enabled, the settings of all the configuration switches are read and the operation of the positioner adjusted accordingly. The **Gain Selector** switch is also read and action will be taken to adjust the gain according to the settings of the calibration switches as described in the previous section. A **Quick-Cal** can be aborted at any time by briefly pressing the **Quick-Cal** button and the previous settings will be retained.

If the **Quick calibration** switch (not to be confused with the **Quick-Cal** button) is set to **Auto** and the valve/actuator assembly has the necessary internal stops, the calibration will complete automatically. While the calibration is in progress you will notice a series of different lights flashing indicating the calibration progress. When the lights return to a sequence that starts with a green



light, the calibration is complete. (See the appendix for an explanation of the various light sequences.)

WARNING: *When operating using local control of the valve, the valve will not respond to external commands. Notify proper personnel that the valve will not respond to remote command changes, and make sure the valve is properly isolated.*

If the *Quick calibration* switch is set to *Jog*, the calibration will initially close the valve then cause a small jump in the valve position. **The jog calibration process will only allow the user to manually set the span; zero position is automatically always set at the seat.** If an elevated zero is needed a handheld or other PC based configuration software is required. The LEDs will then flash in a sequence of Y-R-R-G (yellow-red-red-green) which indicates the user must now use the *Jog* keys to manually position the valve to the desired 100% position. Now press both *Jog* buttons simultaneously to proceed to the next step. The valve will then stroke and then wait while flashing the Y-R-R-G sequence again, allowing the user to adjust the valve position a second time to exactly 100% using the *Jog* buttons. When the stem is properly positioned press both *Jog* buttons simultaneously again to register the 100% position and proceed. No more user actions are required while the calibration process is completed. When the lights return to a sequence that starts with a green light the calibration is complete. (See the appendix for an explanation of the various light sequences.)

9.5 Local control of valve position

Can be done from the user interface by holding both jog buttons and then simultaneously pressing the *Quick-Cal* button. While in this mode the LEDs will flash a Y-G-R-R (yellow-green-red-red) sequence. To exit the local control mode and return to normal operation, briefly press the *Quick-Cal* button.

9.6 Factory reset

Hold *Quick-Cal* button while applying power and all of the internal variables including calibration will be reset to factory defaults. The positioner must be re-calibrated after a factory reset. Tag names and other user configured limits, alarm settings, and valve information will also need to be restored. A factory reset will always reset the command source to analog 4-20 mA.

9.7 Special settings

Several adjustments to the Logix 520si such as split-range, MPC, soft stop, etc. cannot be set using the local interface.

To set these parameters please use SoftTools software or a HART handheld.

11 LIMIT SWITCH UNIT

CAUTION: The installation of hazardous location electrical equipment must comply with the procedures contained in the certificates of conformance. Country specific regulations may apply. Electrical safety is determined only by the power supply device. (Positioner operation with limited voltage only).

11.1 General

The Logix 520si digital positioner can be equipped with an additional limit switch unit.

11.2 Principle of Operation

The lever / coupling moves the vane into the slot of the limit switches LS1 or LS2. The sensors are designed as a proximity vane type switch. The switching function is triggered if a ferromagnetic object (vane) is inserted between the coils. The switching point can be set by adjustment of the vane.

11.3 Installation (Figure 7)

The limit switch unit is fitted to the positioner when delivered but can be retrofitted. Fit 3 spacer screws (1) to positioner housing. Place PC board (2) on spacer screws (1), secure with 3 mounting screws (3).

Switches (Figure 8)

Install vane assembly (4) and secure with 2 screws. For electrical connect see Figure 8.



WARNING: For units installed in Hazardous areas special installation cautions and procedures are required.

11.4 Adjusting switches

Use the following procedure to adjust the switches

1. Loosen the two screws on the vane (4), figure 7.
2. Stroke the valve to the first switching position.
3. Set the switching point of the limit switch by adjusting the lower vane for the lower switch (LS2).
4. Stroke the valve to the second switching position (LS1).
5. Set the switching point of the limit switch by adjusting the vane for the upper switch.
6. Tighten the two screws on the vane (4), figure 7.
7. Check the two switching points and repeat the adjustment steps 1 to 6, if necessary.

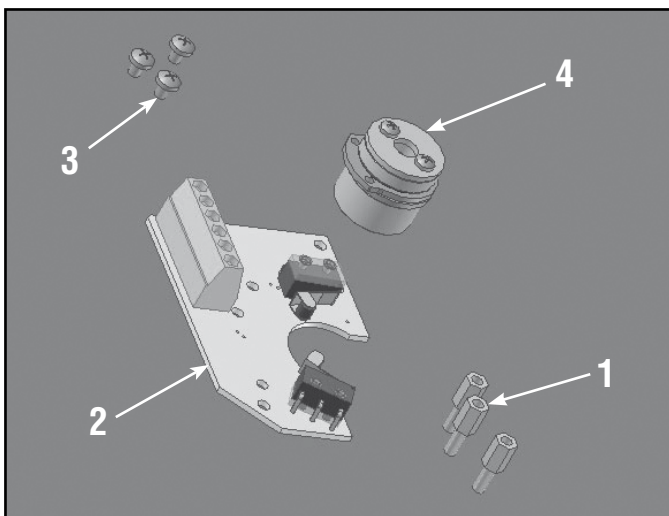

Figure 7: Limit switches

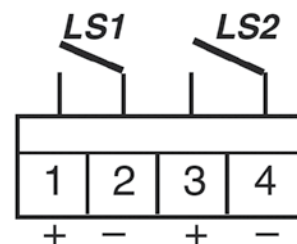
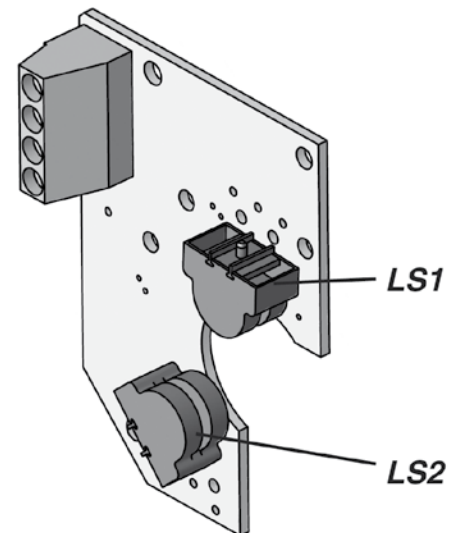

Figure 8: Switch connections

12 STATUS CODES

Colors	Identifier	Indication and resolution
G - - -		Any sequence starting with a Green light flashing first is a normal operating mode and indicates that there are no internal problems.
GGGG	1	No errors, alerts, or warnings; and the unit is in analog control mode.
GGGY	2	MPC active - The command is below the user set limit for tight shutoff feature. This is a normal condition for a closed valve. The factory default setting is 1% command. To clear the condition use handheld or Flowserve supplied software to reset the MPC if the range is incorrect or adjust the command signal above the specified MPC value.
GGYG	3	Digital command mode - The analog 4-20 mA input signal is ignored in this mode and a handheld or Flowserve supplied software is needed to change the position command. (Note a factory reset is the only method to reset the command back to analog control mode from the local interface if a PC or handheld configurator is not available. A reset will cause the loss of other data).
GGYR	4	Initializing, or LED test mode - This sequence should only be visible for 3 sequences when powering up the unit.
GGRG	5	Cycle limit - The cycle limit set by the user has been exceeded. To clear use handheld or Flowserve supplied software to reset.
GGRY	6	Travel limit - The total accumulated travel limit set by the user has been exceeded. To clear use handheld or Flowserve supplied software to reset.
GYR	7	Soft Stop Lower - The unit is being commanded to exceed a user defined lower travel limit and the internal software is holding the position at the limit. To clear the condition use handheld or Flowserve supplied software to reset the limit if more travel is needed or adjust the command signal back in the specified range.
GYRY	8	Soft Stop Upper - The unit is being commanded to exceed a user defined upper travel limit and the internal software is holding the position at the limit. To clear the condition use handheld or Flowserve supplied software to reset the limit if more travel is needed or adjust the command signal back in the specified range.
GRYR	9	Position Lower - The position has reached or is exceeding a user defined lower travel indicator similar to a limit switch indicator. To clear the condition use handheld or Flowserve supplied software to reset the indicator if more travel is needed or adjust the command signal back in the specified range.
GRRY	10	Position Upper - The position has reached or is exceeding a user defined upper travel indicator similar to indicator if more travel is needed or adjust the command signal back in the specified range.

Colors	Identifier	Indication and resolution
Y - - -		Any sequence starting with a yellow light indicates that the unit is in a special calibration or test mode, or that there was a calibration problem.
YGYG	11	Signature test in progress - This is a test initiated by Flowserve supplied software that can only be cancelled by that software.
YYYG	12	Loop Calibration in Progress - Calibration sequence controlled by a handheld or Flowserve supplied software that can only be cancelled by that software.
YRGG	13	Stroke Calibration in Progress - Calibration sequence started either using the local Quick-Cal button or by a handheld or Flowserve supplied software. It may be cancelled by briefly pushing the Quick-Cal button.
YGRR	14	JOG Control Mode - the unit has been placed in a local override mode where the valve can only be stroked using the two local jog buttons. It may be cancelled by briefly pushing the Quick-Cal button.
YYR	15	Command 0 saturated - Calibration error indicating that the 4-20 mA signal corresponding to 0% position was out of range. Adjust the signal to the correct range and re-do the calibration. This error may be cleared by briefly pushing the Quick-Cal button, which will force the positioner to use the parameters from the last good calibration.
YYRY	16	Command 100 saturated - Calibration error indicating that the 4-20 mA signal corresponding to 100% position was out of range. Adjust the signal to the correct range and re-do the calibration. This error may be cleared by briefly pushing the Quick-Cal button, which will force the positioner to use the parameters from the last good calibration.
YYRR	17	Command span - Calibration error indicating that the 4-20 mA signal was below the minimum calibration span. The minimum calibration span is 1.28 mA. This error may be cleared by briefly pushing the Quick-Cal button, which will force the positioner to use the parameters from the last good calibration.
YRRG	18	Waiting for JOG set point from User - only used during Jog calibration see explanation in Quick-Cal section of main document for operation.
YRYG	19	Setting IL Offset (in Stroke Cal) - An automatic step in the calibration process that is done with the valve at 50% position. This must be completed for proper calibration.
YRY	20	Feedback no-motion during calibration - Indicates that there was no motion of the actuator based on the current stroking time configuration. Check linkages and air supply to make sure the system is properly connected. If the time out occurred because the actuator is very large then simply retry the Quick-Cal and the positioner will automatically adjust for a larger actuator by doubling the time allowed for movement. This error may be cleared by briefly pushing the Quick-Cal button, which will force the positioner to use the parameters from the last good calibration.
YRYR	21	Feedback 0 saturated - Calibration error indicating that the position sensor was out of range during the calibration. To correct the condition, adjust the positioner mounting, linkage or feedback potentiometer to move the position sensor back into range then restart the calibration. This error may be cleared by briefly pushing the Quick-Cal button, which will force the positioner to use the parameters from the last good calibration.
YRRY	22	Feedback 100 saturated - Calibration error indicating that the position sensor was out of range during the calibration. To correct the condition, adjust the positioner mounting, linkage or feedback potentiometer to move the position sensor back into range then restart the calibration. This error may be cleared by briefly pushing the Quick-Cal button, which will force the positioner to use the parameters from the last good calibration.
YRRR	23	Feedback span - The range of motion of the position feedback arm was too small. Check for loose linkages and/or adjust the feedback pin to a position closer to the follower arm pivot to create a larger angle of rotation. This error may be cleared by briefly pushing the Quick-Cal button, which will force the positioner to use the parameters from the last good calibration.
YRGR	24	Feedback unstable during calibration - Check for loose linkages or loose position sensor. This error may be cleared by briefly pushing the Quick-Cal button, which will force the positioner to use the parameters from the last good calibration.
YRGY	25	Feedback unstable setting IL Offset - Check for loose linkages or loose positioner sensor. This can also be caused by over tightened packing, very sticky packing, or very high gain settings. This error may be cleared by briefly pushing the Quick-Cal button, which will force the positioner to use the parameters from the last good calibration.

Colours	Identifier	Indication and resolution
R - - -		Any sequence starting with a red light indicates that there is an operational problem with the unit.
RGRR	26	Position Deviation - The position has exceeded user defined error band between command and position.
RYYY	27	Hall sensor non-motion - Check to make sure the air supply is connected. This error may be cleared by briefly pushing the Quick-Cal button, which will force the positioner to use the parameters from the last good calibration. If the positioner still does not operate replace the pneumatic relay assembly.
RYYR	28	Hall sensor lower position - Check to make sure the air supply is connected. This error may be cleared by briefly pushing the Quick-Cal button, which will force the positioner to use the parameters from the last good calibration. If the positioner still does not operate replace the pneumatic relay assembly.
RRYR	29	Hall sensor upper position - Check to make sure the air supply is connected. This error may be cleared by briefly pushing the Quick-Cal button, which will force the positioner to use the parameters from the last good calibration. If the positioner still does not operate replace the pneumatic relay assembly.
RRGG	30	1,23 V reference - Bad electronic assembly, replace.
RRGR	31	12-bit A/D reference - Bad electronic assembly, replace.
RRYG	32	Temperature limit - The internal positioner temperature is currently exceeding operational limits of -40 °C (-40 °F) or 85 °C (185 °F).
RRYY	33	Piezo voltage - Bad electronic assembly, replace.
RRYR	34	Board current high - Check internal wiring and connectors for electrical shorts, if no shorts bad electronic assembly, replace.
RRRG	35	12-bit D/A reference - Bad electronic assembly, replace.
RRRY	36	EEprom checksum error - The checksum of the internal data has become corrupted. Cycle power and complete a Quick-Cal if needed. Check internal data to verify correct settings. If the error still occurs, bad electronic assembly, replace.

13 VERSION NUMBER CHECKING

The version number of the embedded code may be checked at any time except during a calibration by holding down the Δ button. This will not alter the operation of the unit other than to change the blink sequence to 3 blinks indicating the major version number. Holding the ∇ button will give the minor version number without affecting operation. The version codes are interpreted by adding up the numbers assigned according to the following table:

Color	First blink value	Second blink value	Third blink value
Green	0	0	0
Yellow	9	3	1
Red	18	6	2

For example if holding the Δ button gave a G-G-R code, and holding the ∇ button gave a Y-Y-G code then the resulting version number would be (0+0+2).(9+3+0) or version 2.12.

14 TROUBLE SHOOTING

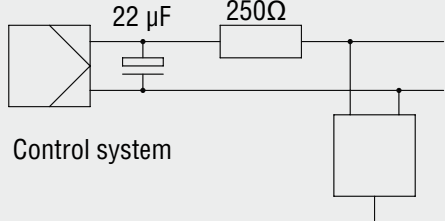
Logix 520si Symptoms and Solutions		
Failure	Probable Cause	Corrective action
No LED is blinking	<ol style="list-style-type: none"> 1. Current source below 3,7 mA 2. Incorrect wiring polarity 	<ol style="list-style-type: none"> 1. Verify current source supplies at least 3,7 mA 2. Check wiring for correct polarity
Erratic communications	<ol style="list-style-type: none"> 1. Current source bandwidth not limited to 25Hz 2. Maximum cable length or cable impedance exceeded 3. HART modem connected to PC RS-232 port not receiving enough power 4. Interference with I.S. barrier 5. Current source stripping (filtering) HART signal 	<ol style="list-style-type: none"> 1. Maximum allowable current source rate of change is 924 mA per second 2. Check cable conductor size, length and capacitance. Refer to 'Cable Requirements' on page 11. 3. Verify laptop battery is not low 4. Must use HART compatible I.S. barrier 5. Use the HART filter (VHF) available from Flowserve (FLS part-No. 10156843) Alternatively a 250Ω and a 22 μF capacitor, installed according to the following schematic drawing can be used to establish communication 
Unit does not respond to analog commands	<ol style="list-style-type: none"> 1. Unit is in digital command mode 2. Error occurred during calibration 	<ol style="list-style-type: none"> 1. Switch to analog command mode with ValveSight DTM software or handheld communicator. 2. Correct calibration error. Recalibrate
Valve position reading is not what is expected	<ol style="list-style-type: none"> 1. Stem position sensor mounting is off 180 degrees 2. Stroke not calibrated 3. Tight shutoff MPC (Minimum position cutoff) is active 4. Custom characterization or soft stops active 	<ol style="list-style-type: none"> 1. Reposition sensor 2. Calibrate stroke 3. No action 4. No action
Position is driven fully open or closed and will not respond to command	<ol style="list-style-type: none"> 1. Stroke not calibrated 2. Inner-loop hall sensor not connected 3. Wrong air action entered in software 4. Actuator tubing backward 5. Electro-pneumatic converter malfunctioning 6. Control parameter inner-loop offset is too high/low 	<ol style="list-style-type: none"> 1. Calibrate valve stroke 2. Verify hardware connections 3. Check ATO (Air-to-open) and ATC (Air-to-Close) settings. Recalibrate 4. Verify ATO/ATC actuator tubing 5. Replace electro-pneumatic converter 6. Adjust inner-loop and see if proper control resumes
Sticking or hunting operation of the positioner	<ol style="list-style-type: none"> 1. Contamination of the electro-pneumatic converter. 2. Control tuning parameters not correct 	<ol style="list-style-type: none"> 1. Check air supply for proper filtering and meeting ISA specifications ISA-7.0.01 2. Lower proportional gain settings

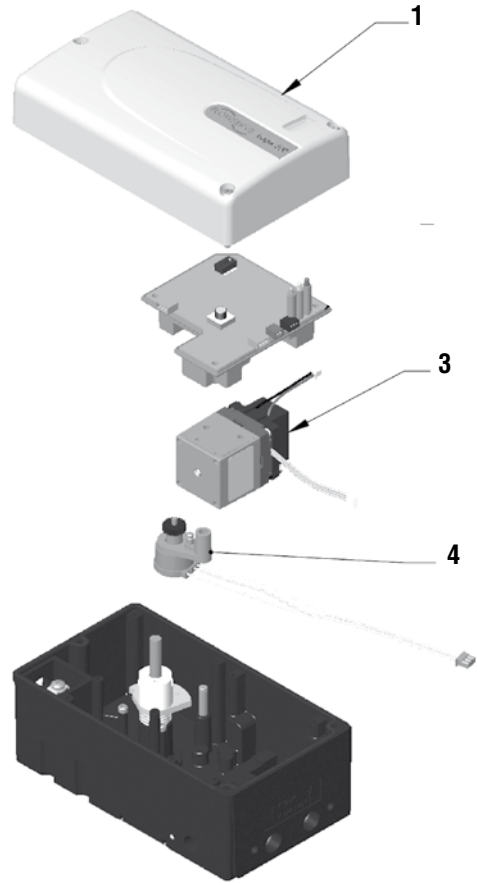

Figure 9: Exploded drawing for spare parts

15 SPARE PARTS KITS

Item No.	Description		Part-No.
1	Cover Assembly	Yellow	255240.999.000
		White	218771.999.000
		Black	218772.999.000
3	Relay Module Assembly: -20°C to 85°C (-4°F to 185°F)		230103.999.000
	Relay Module Assembly: -40°C to 85°C (-40°F to 185°F)		218773.999.000
4	Repair kit for Potentiometer Assembly		218774.999.000
5	Position Feedback Assembly		218774.999.000
8	Follower Arm Assembly	Max. stroke 65 mm	214323.999.000
		Max. stroke 110 mm	214322.999.000

Mounting Kits

	Description	Part-No.
-	IEC 534 part 6 (FloTop, Kämmer KA, Kämmer KP, and standard NAMUR linear valves)	213619.999.000
-	Rotary VDI/VDE 3845 (DIN ISO 5211)	188151.999.000
-	Flowserve direct mounting	214004.999.000
-	Linear VDI / VDE 3847	255242.999.000

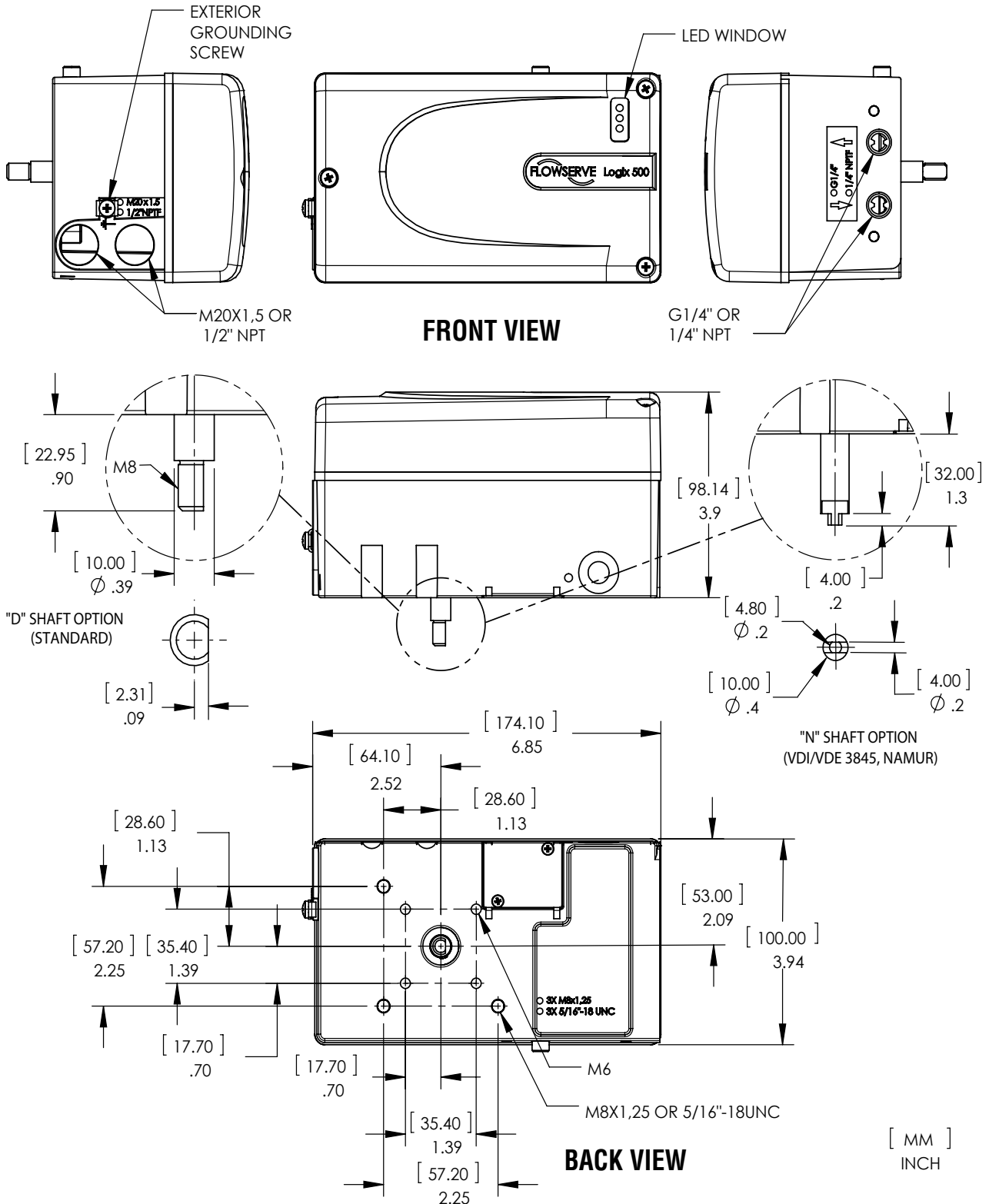
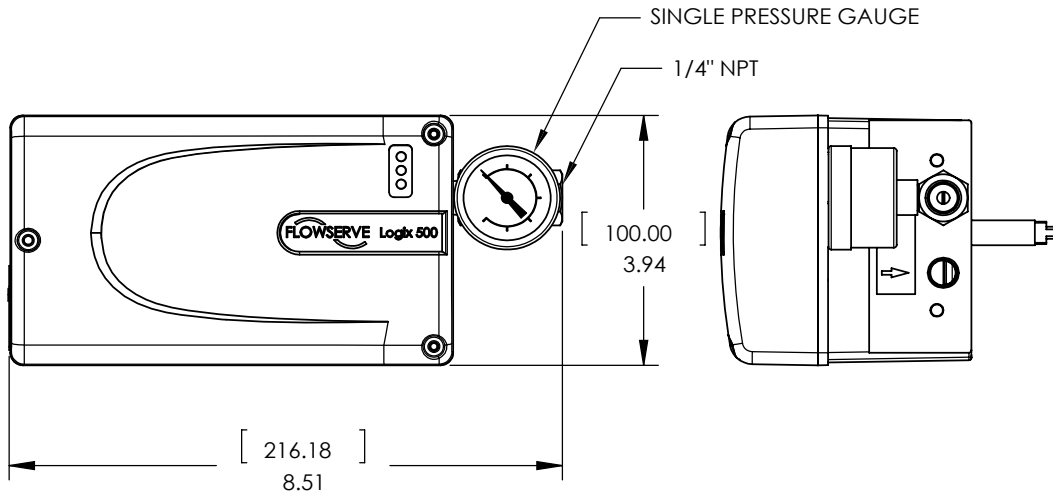
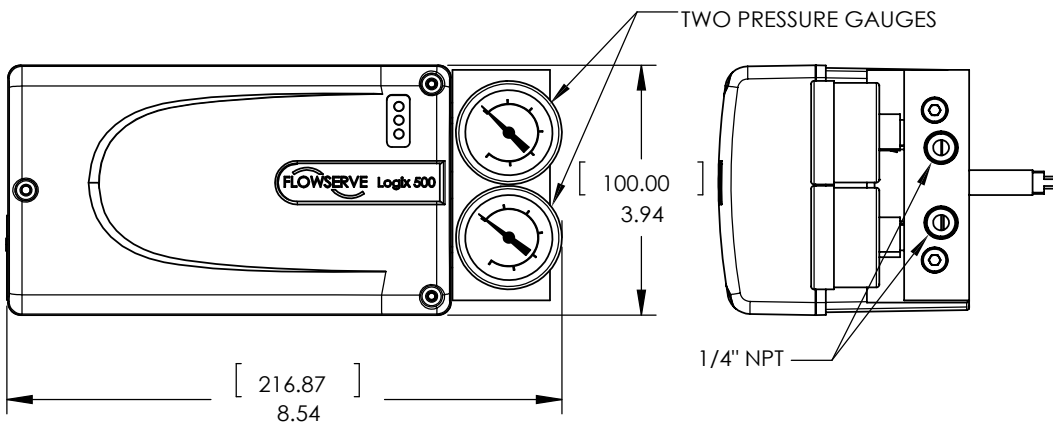

Figure 10: Dimensional Drawing for the Logix 520si Series Digital Positioner



AUXILIARY OPTIONS - "GA" (GAUGE ADAPTER)



AUXILIARY OPTIONS - "GM" (GAUGE MANIFOLD)

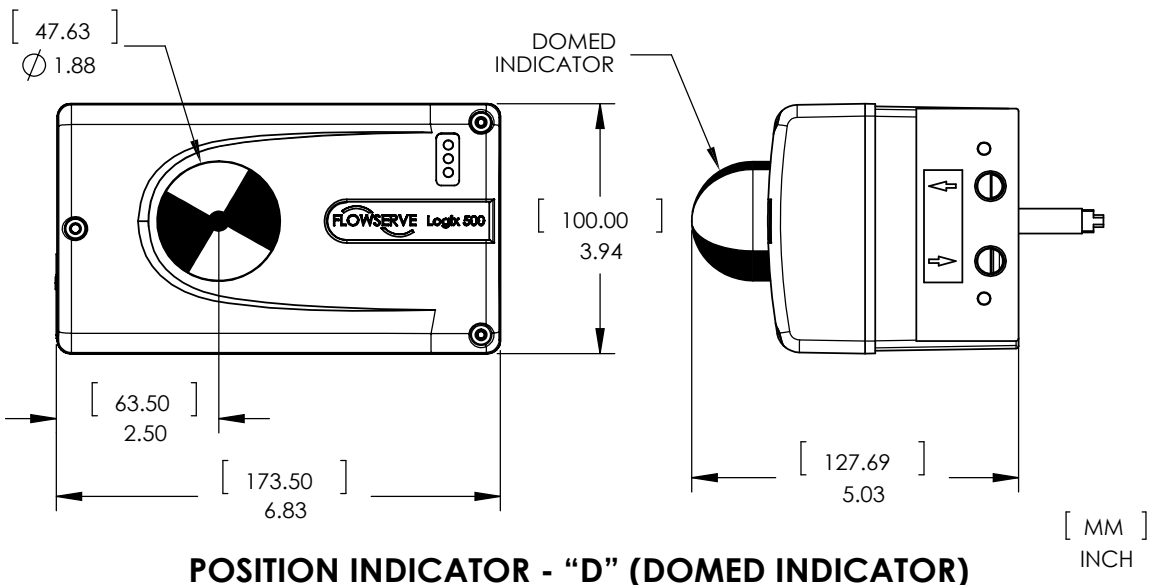

POSITION INDICATOR - "D" (DOMED INDICATOR)

Figure 11: Dimensional Drawing for the Logix 520si with options